

--

-

-

•

•

•

•

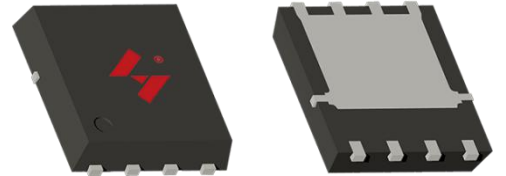

•

•

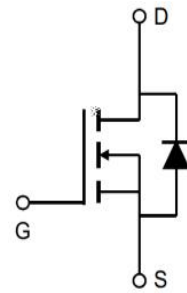

-

-

-

-

	
---	--

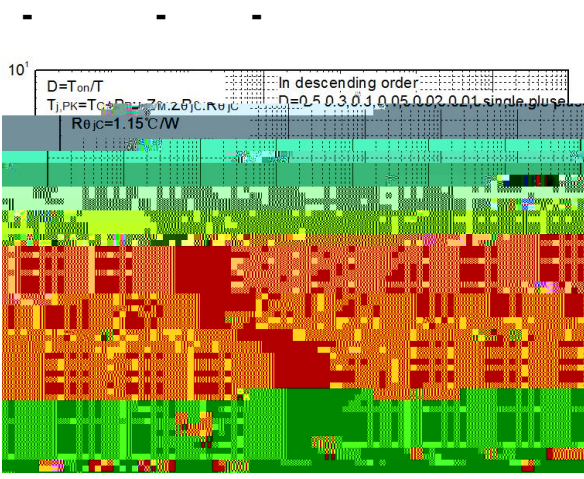
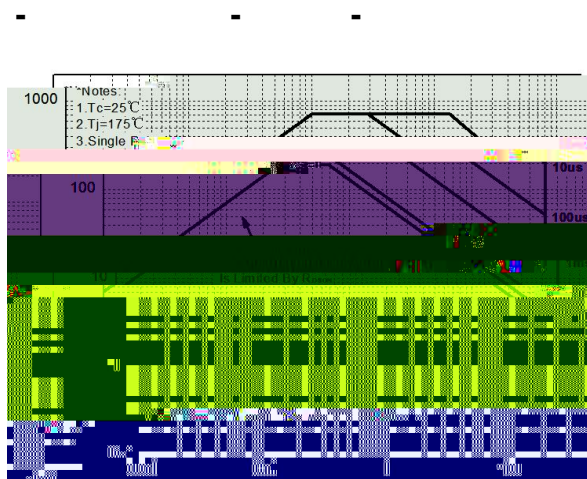
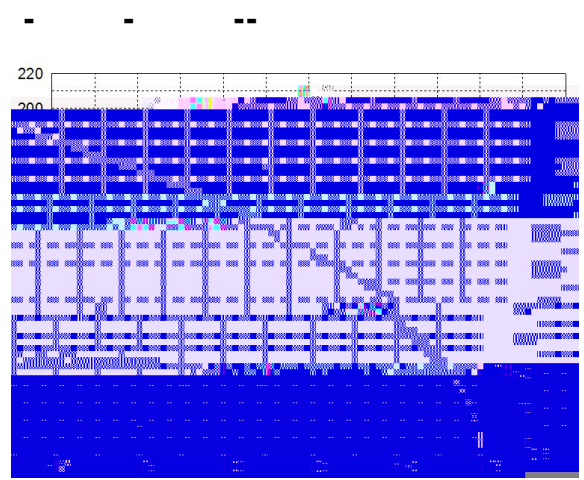
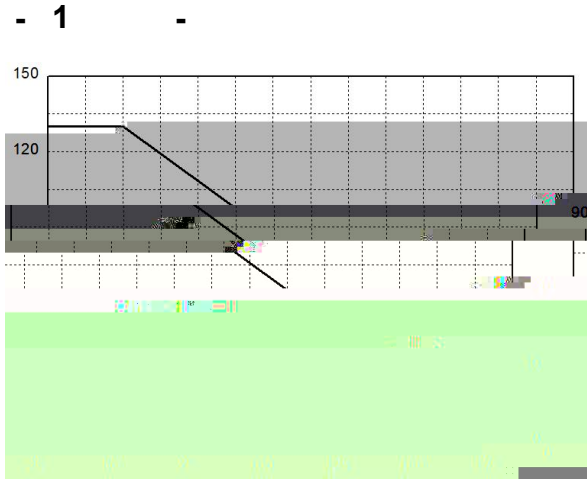

Maximum Effective Transient Thermal Impedance Junction Case

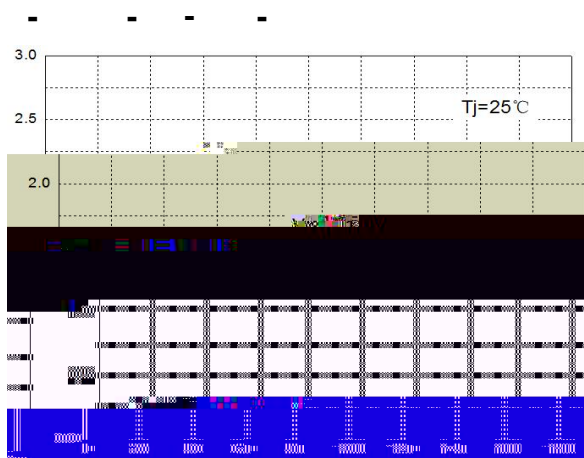
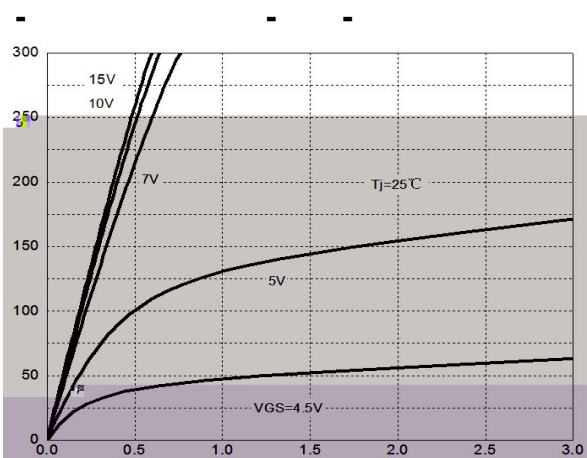

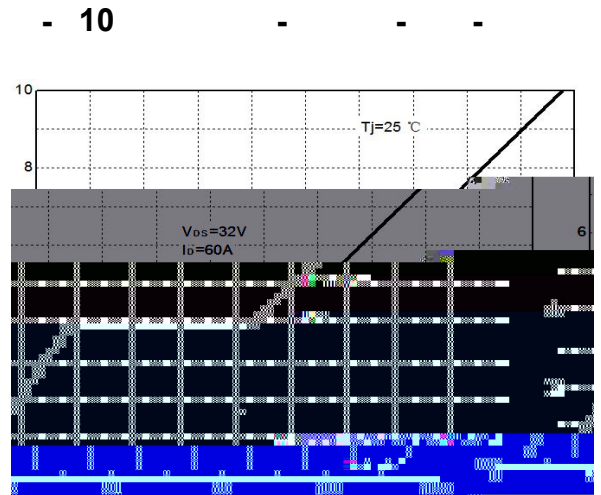
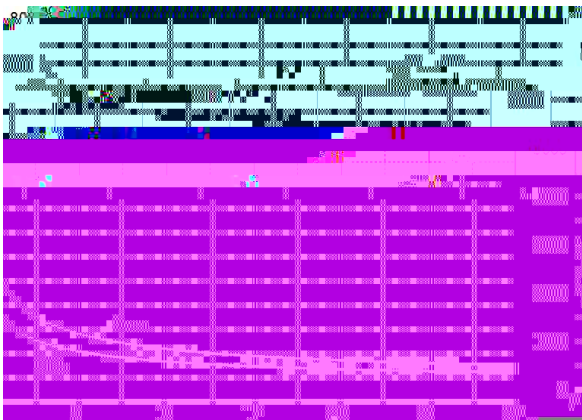
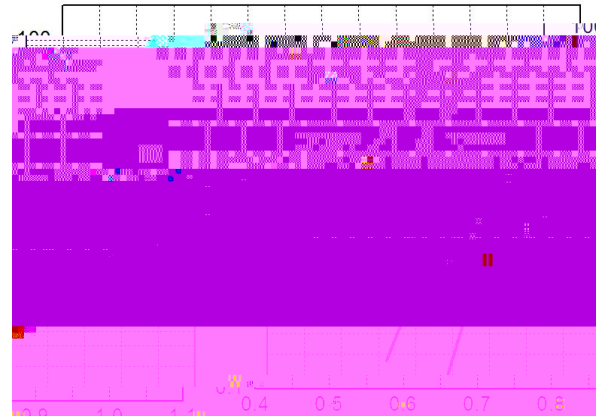
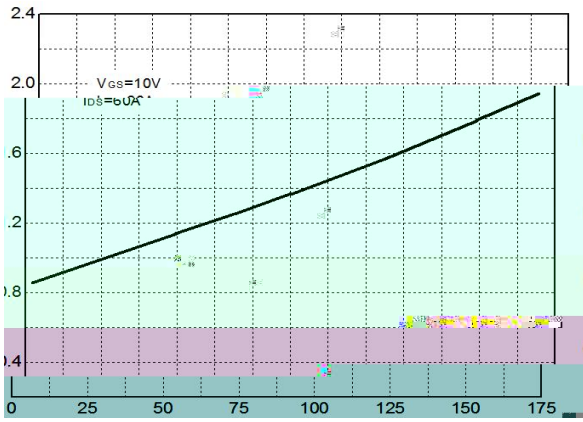

(

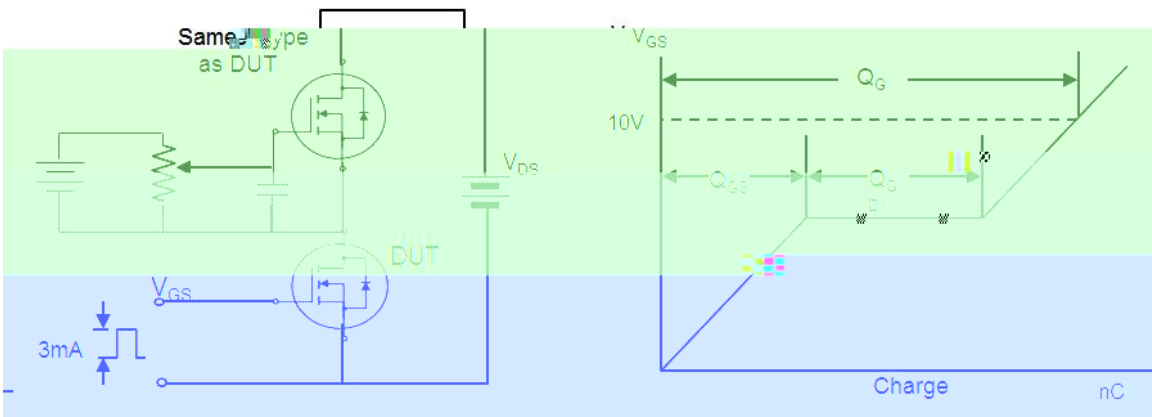
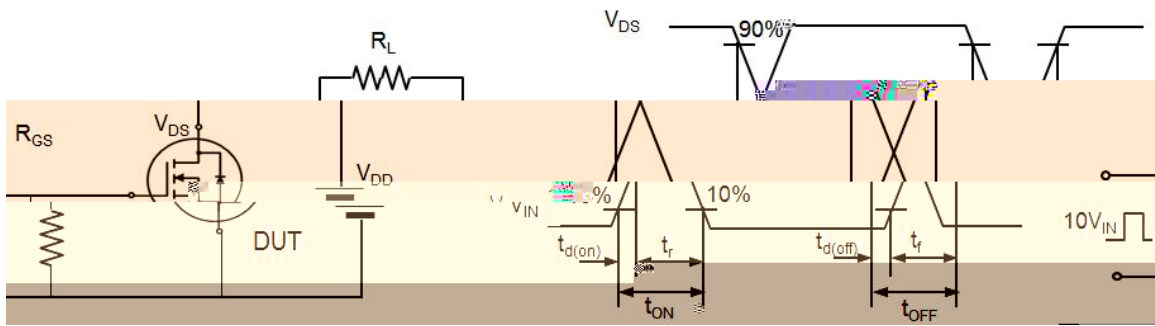
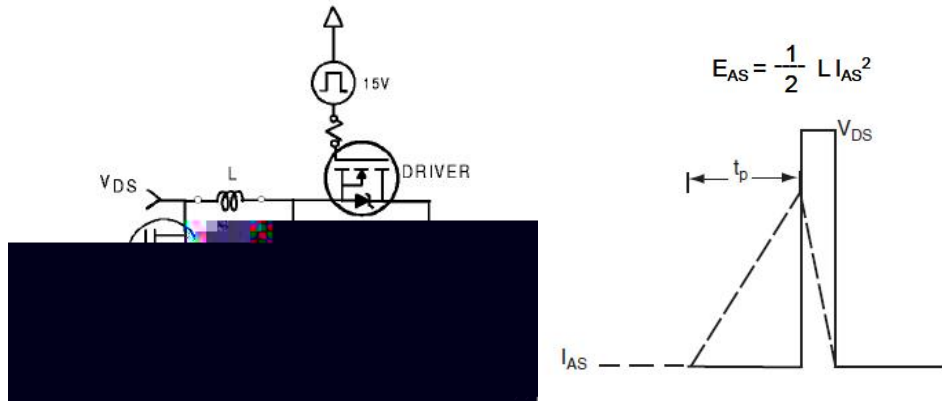

(-

-

& (

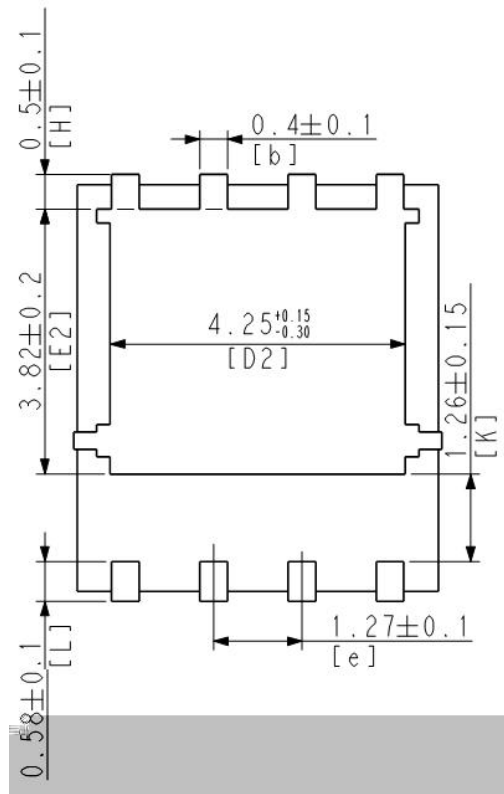
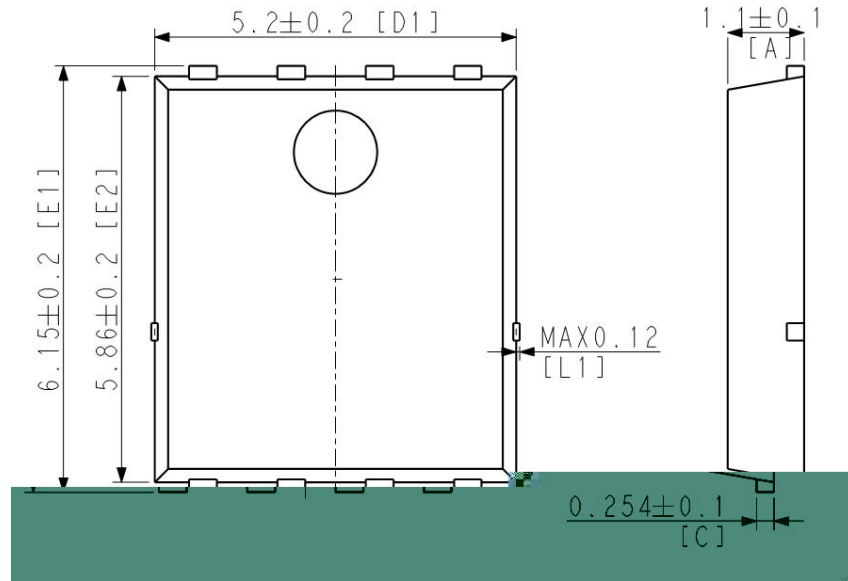

	0	0

	0	0-000	000

- -

		-

- -(
